



120-185 HP | **MF 6600**



FROM MASSEY FERGUSON

Contents



Page 04
Compact and Manoeuvrable, with a perfect power-to-weight ratio



Page 10
The most powerful, compact 4 cylinder tractor available



Page 16
The Dyna transmissions



Page 22
Welcome to the work place - you won't want to leave



Page 32
Seamless integration of loader and tractor



Page 34
Best in Class, Manoeuvrability and traction



Page 36
Power and Performance to tackle the task

- 03 Centre of Engineering and Manufacturing Excellence
- 04 Compact and Manoeuvrable, with a perfect power-to-weight ratio
- 06 Concentrated power and energy
- 08 Features that fulfil every need
- 10 The most powerful, compact 4 cylinder tractor available
- 12 SCR technology - silently saving you money
- 14 Engine power management
- 16 The Dyna transmissions
- 18 Dyna-4 and Dyna-6
- 20 Dyna-VT
- 22 Welcome to the workplace - you won't want to leave
- 24 Essential - the new standard for straightforward operation
- 26 Efficient - advanced equipment to boost work accuracy
- 28 Exclusive - the ultimate expression of productivity and innovation
- 30 The Essential Panoramic cab option
- 32 Operate your loader the Massey Ferguson way
- 34 Best in Class, Manoeuvrability and traction
- 36 Power and Performance to tackle the task
- 38 Oil flow to power the most demanding implements
- 40 All Fused with Straightforward On-board Technologies
- 42 The CCD Console
- 44 Guidance options to keep you on track for profit
- 46 Servicing made easy
- 47 Total Support
- 48 Standard and optional equipment
- 50 Specifications

Beauvais, France | Centre of Engineering and Manufacturing Excellence



The €250m investment made over the last five years in the Beauvais tractor plant, home of Massey Ferguson's high range of tractors, has been carried out with a singular aim: to ensure Massey Ferguson tractors are built to standards of quality, reliability and productivity that guarantee peace of mind for the owners and operators who depend on them. More than 870,000 tractors have been built in Beauvais since it was opened in 1960, and farmers in over 140 countries rely on its products.

The 2500 staff employed at the Beauvais site take particular pride in the products they design and manufacture, and while as many as 90 tractors a day leave the line, each one is crafted with the utmost care and attention. That focus on quality is coupled with Massey Ferguson's reputation as a leader in developing and offering innovative and pioneering solutions with clear, measurable benefits, such as fuel-saving Selective Catalytic Reduction (SCR), which we were first to bring to the market. The result is tractors which help you farm more productively and more efficiently.

Continuous research and development into making machines that do more for those that own and operate them has been part of the reason Massey Ferguson has won more independent innovation awards than any other manufacturer. As farmers' needs continue to evolve, that R&D commitment remains as strong as ever.



Compact, Manoeuvrable, with a perfect power-to-weight ratio

The Massey Ferguson DNA clearly runs through the MF 6600 range, with the same familiar, contemporary styling and a presence that makes every MF tractor stand out from the crowd. Ruggedly powerful engines and intelligent design ensure all models have a high power-to-weight ratio for extraordinary all-round machine ability and agility in all applications.

At first sight, you'll find that the MF6600 Series is a true blend of light build with heavyweight design, nimble yet powerful, with masses of torque yet without masses of weight – unless you choose to add it. The result is a tractor that combines concentrated energy and power density, suiting perfectly the needs of those seeking a machine with compact dimensions, yet with the carrying and power capacity at each end to lift and drive the very latest implements.

MF6600





MF 6600

With the new MF 6600 Series, Massey Ferguson introduces the very latest in 4 cylinder engine technology to a power band that previously was the domain of 6 cylinder tractors. The MF 6600 blends all the benefits of a 4 cylinder machine – compact dimensions, low overall weight, good manoeuvrability – with the pulling, pushing and lifting power to match a comparable 6 cylinder tractor. With a maximum output of 185hp (with engine power management) on the MF 6616 Dyna-6, the new MF 6600 Series offers the highest performance of any 4 cylinder tractor on the market today. All models show perfect power-to-weight ratio for extraordinary all-round machine ability and agility in all applications.

The Massey Ferguson DNA that runs through all MF tractors is immediately apparent upon first glance at the MF 6600 models. They take styling and design cues from the smaller ranges and the larger MF 8700 tractors, with features that have proven themselves straightforward, dependable, practical and valuable on those machines. But our engineers recognise that, in this 100hp to 200hp power bracket, it's essential for a tractor to be versatile, flexible, suited to the whole spectrum of tasks across arable, mixed and dairy farm businesses, as well as contracting operations.

With five models in the range, spanning max powers of 135hp to 185hp, there is an MF 6600 tractor to match every size and type of operation. A choice of three specification levels and three transmissions – Dyna-4 four-speed and Dyna-6 six-speed powershifts, plus Dyna-VT CVT – means that MF 6600 tractors can be ordered in any one of 21 different combinations to meet your exact requirements.

Concentrated power and energy

The most powerful 4 cylinder tractor available today

Transmission type	Dyna-4			Dyna-6				Dyna-VT		
Model	6612	6613	6615	6613	6614	6615	6616	6614	6615	6616
ISO max hp	120	130	145	125	140	150	160	140	150	160
ISO max hp EPM*	135	145	160	150	165	175	185	-	-	-
Cab versions	Essential			Essential, Efficient, Exclusive				Efficient, Exclusive		

*Dyna-4 models: Engine Power Management engages above 6 Km/h.

*Dyna-6 models: Engine Power Management engages above 6 Km/h and also in PTO applications, delivering maximum extra power when both forward speed and PTO requirements apply.

Highlights

- The most powerful 4 cylinder tractor in the market today with up to 185hp
- Available with a choice of transmissions for a wide range of applications : Dyna-4, Dyna-6 and Dyna-VT
- The MF 6600 can be specified with Essential, Efficient or Exclusive specification levels to perfectly suit your requirements
- High versatility: Perfect for dairy units, mixed farms, arable enterprises and contracting businesses



MF 6600



BodyScan your MF 6600 ! Features that fulfil every need

With the MF 6600 range, Massey Ferguson makes available in the 100hp to 200hp bracket features you might usually expect to find only on really high horsepower models, all packed in a compact format.

01 AGCO POWER Engines

The very latest 2nd generation SCR with 4.9 litre capacity that provide the perfect blend of power, weight and compact dimensions with the ultimate in fuel efficiency for maximum performances without compromise.

02 Fuel and AdBlue® tank

New large fuel and urea tanks enable extra long working days while offering easy accessibility and good ground clearance without impeding cab access

03 Massey Ferguson unrivalled look

A single-piece hinged bonnet, with unique Massey Ferguson styling offers a clean look providing easy access for engine servicing and inspection, with a waisted design for excellent manoeuvrability and visibility

04 Three Levels of Cab Specification

Three specification levels – Essential, Efficient, Exclusive – to allow tractors to be tailored to individual customers' requirements and budgets

05 Cab suspension option for extra ride comfort

The cab offers the most comfortable and productive working environment in its class, with mechanical and Optiride hydraulic suspension options

06 Packed with straightforward onboard technologies

Auto-Guide™ 3000 auto-steering and AGCOMMAND™ telemetry options. Auto-Guide™ 3000 now fully available through the optional CCD Console

07 Ultimate transmissions choice

Drive options including Dyna-4 and Dyna-6 powershifts, plus the Dyna-VT continuously variable transmission. Dyna-4 and Dyna-6 come with Engine Power Management for extra power delivery in more demanding applications.

08 Hydraulics

Powerful hydraulics to provide 58, 100 or 110 l/min of oil flow via up to four double-acting spool valves and an electronically-controlled linkage

09 Front Linkage for maximum productivity in the field

A front linkage and PTO which are seamlessly integrated into the front end of the tractor, for full strength yet complete convenience, alongside the 4WD axle and optional front suspension

10 Battery Installation

A new battery installation that provides excellent safety and security

* Dependent on versions. See specifications and don't hesitate to ask your local MF Dealer or Distributor for more details.

MF 6600

The most powerful, compact 4 cylinder tractor available

An increasing number of farmers seeking tractors in the 100hp to 200hp bracket are realising the benefits of a 4 cylinder tractor. A lighter footprint, better manoeuvrability and extra payload possibilities are just some of the ways in which, for some operators, a 4 cylinder machine can make more sense than a 6 cylinder tractor in this bracket.

Back in 2008, Massey Ferguson led the industry in bringing SCR to the agricultural machinery sector as a means not only of meeting our commitment to the environment, but also of improving fuel efficiency for farmers, bringing direct, tangible benefits with the technology. Massey Ferguson works closely with AGCO's dedicated diesel engine arm, AGCO Power, to ensure our tractors are a seamless match with the engines of our sister company. Our collective experience in common rail fuelling and selective catalytic reduction (SCR) for emissions control means that our tractors work in harmony with their engines – and vice versa. As AGCO Power and Massey Ferguson share the same parent company, you can rest assured we will always work together for your benefit.

The MF 6600 Series is a prime example of our combined efforts to refine the efficiency of common rail fuel technology and meet the specific needs of tractor owners in this power class. From our developments has come the highest horsepower 4 cylinder tractor available in the market, offering up to 185hp (with Engine Power Management) courtesy of a fuelling system which calculates precisely the fuel required by the engine at any given moment, responding to the load placed upon it by transport, field, PTO or hydraulic applications. The result: optimum combustion and a cleaner, more powerful, more economical and more reliable engine that produces high levels of torque at low rpm. A 'no compromise' combination.

The clever design of the cooling package allows for a very efficient unit ▶

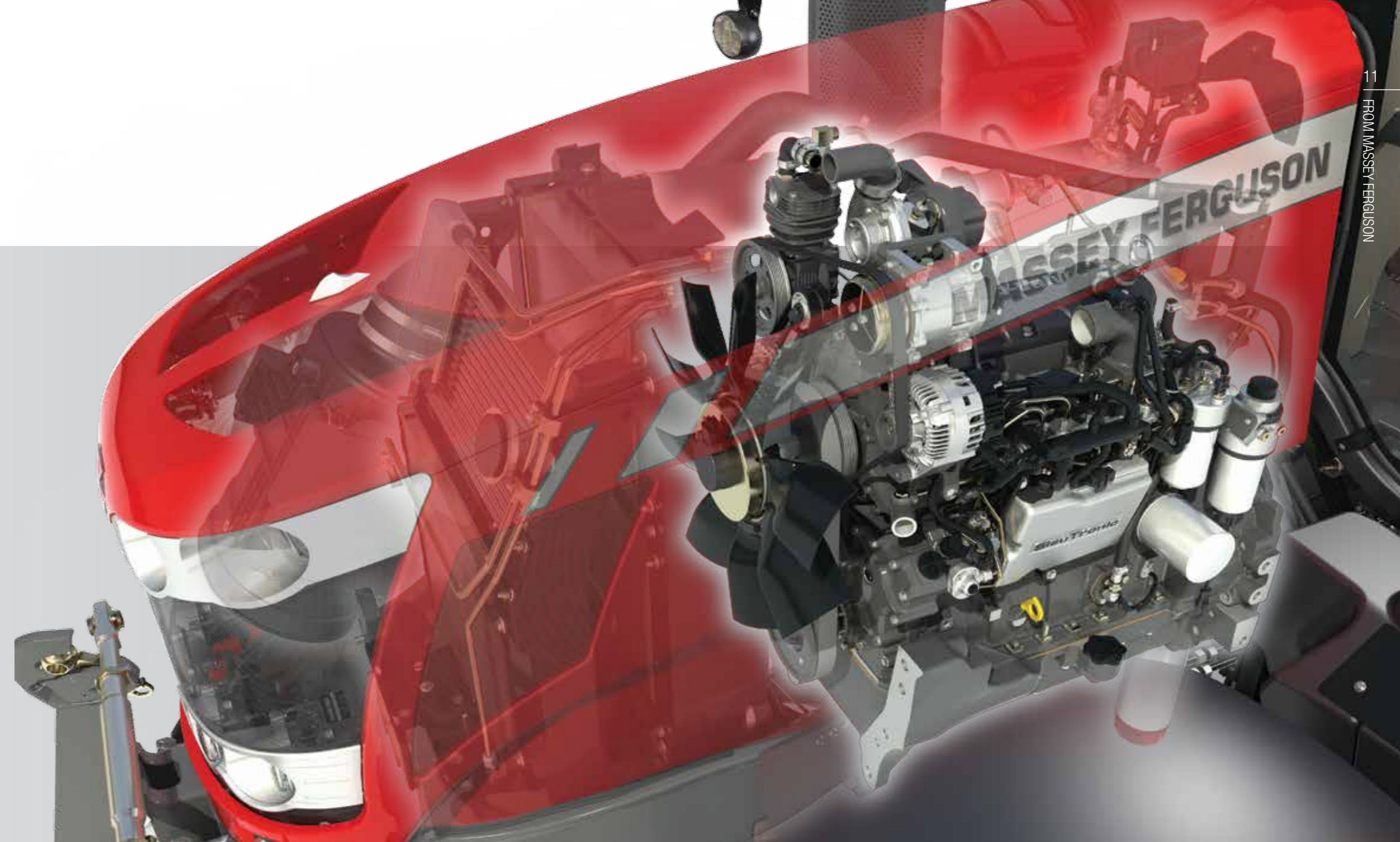

SCR technology:

silently saving you money while providing outstanding engine efficiency

Operating unobtrusively in your tractor's engine, selective catalytic reduction (SCR) technology, working with a diesel oxidation catalyst (DOC), doesn't just benefit the environment through cleaner exhaust emissions. The combination of SCR and DOC, plus the addition of diesel exhaust fluid (DEF/AdBlue®) makes for a more efficient engine, particularly as there is no requirement for extra cooling needs.

AdBlue® is injected into the DOC, vaporising in the exhaust gas stream. Hot exhaust gas then crosses the catalyser, where the heat of the gas causes its nitrous oxide content to react with the AdBlue® to produce ammonia, while carbon monoxide, gaseous hydrocarbons and particulate matter are oxidised, a catalyst (two on the MF 6616) in the exhaust then changing them into harmless nitrogen and water. Because the engine emissions are controlled externally, in the exhaust gas system, you'll benefit from optimised engine performances, maximum power efficiency and highest fuel economy. Filling up with AdBlue® can be done when filling with fuel, and no further additional activity is required.

The only impact on your business is a positive one – on your fuel bills.

Adblue® tank can be filled with ease at the same time as refuelling

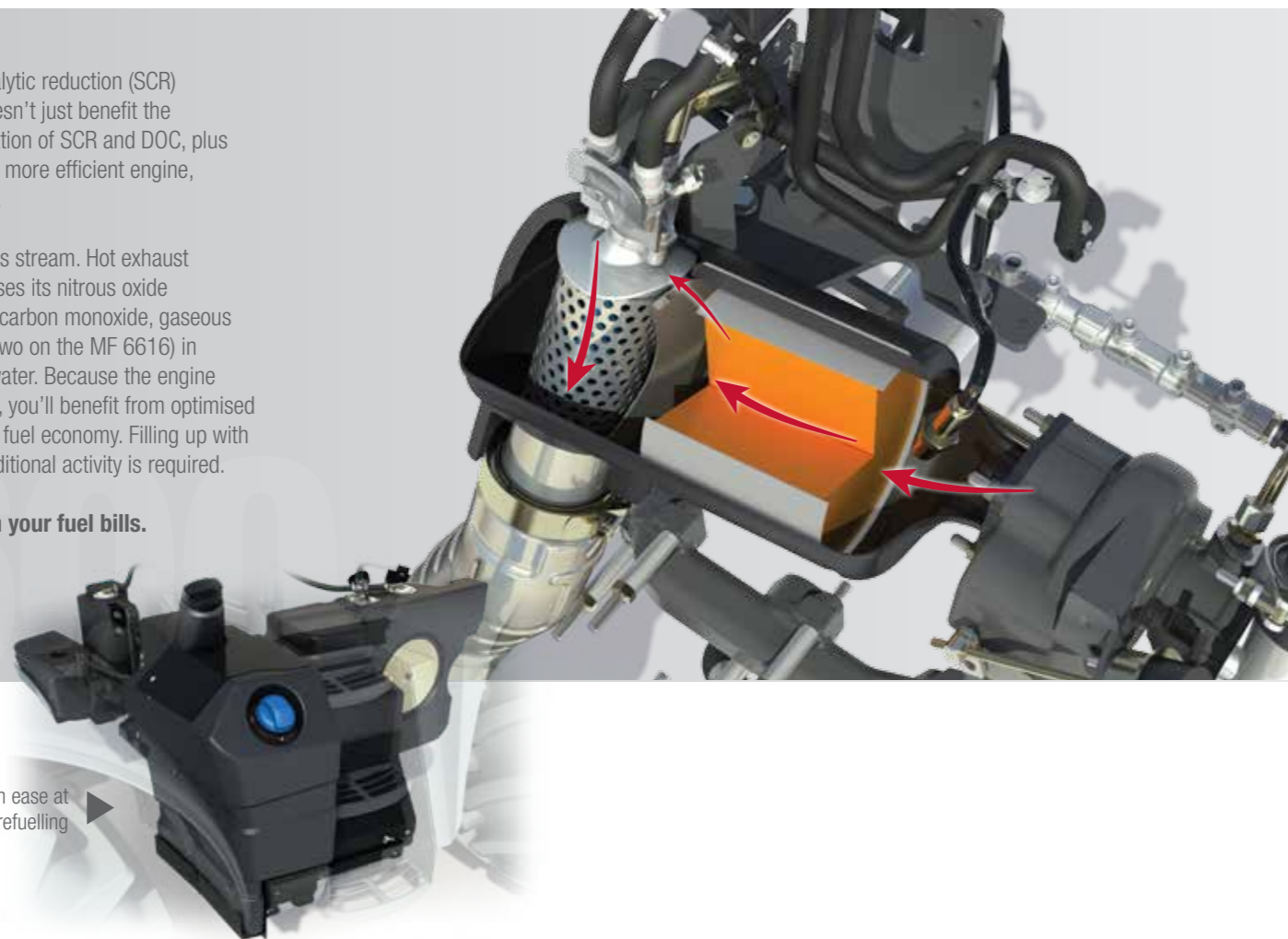

Highlights

Engine Highlights:

- AGCO POWER four cylinder, 4.9 litre engines generate maximum powers of 120hp up to 185hp
- Maintenance free, 2nd Generation Selective Catalytic Reduction (SCR) technology
- Electronically controlled common-rail fuel injection
- Automatic low idle system cuts engine revs to save fuel when idling
- Efficient and smartly designed cooling package provides a compact engine unit



Selective Catalytic Reduction (SCR)

Selective Catalytic Reduction (SCR) process with the Diesel Oxidation Catalyser (DOC)

01. The exhaust gases leave the turbocharger and enter the DOC cylinder.
02. The exhaust gases go through the Diesel Oxidation Catalyst (yellow). Carbon monoxide (CO), gaseous hydrocarbons (HC) and particulate matter (PM) are neutralised here. Nitrogen oxides are prepared to react with the urea.
03. Carefully controlled injection of AdBlue® occurs.
04. The gases that have mixed with the AdBlue® leave the DOC cylinder to reach the exhaust pipe which contains the catalyst.
05. As the gases pass through the catalyst, the NO^x is converted into harmless nitrogen and water.
06. Clean air and water vapour leave the exhaust pipe.



Engine power management: more muscle when you need it

Imagine a tractor that responds automatically to the load imposed on it, and adjusts fuelling accordingly to give you extra power when you need it most. MF 6600 Dyna-4 and Dyna-6 tractors benefit from Engine Power Management, providing a power boost designed to tackle tough transport and PTO work. Advanced electronic engine and transmission management makes more power automatically available under load or at speed.

EPM works by way of transmission electronics which monitor the load and operating conditions within the transmission and PTO according to forward speed, transmission load and PTO activation. This information is then communicated to the electronic engine management system, which then regulates accordingly the very exact quantity of fuel required.

Extra power automatically becomes available above 6 km/h on both Dyna-4 and Dyna-6 tractors, while Dyna-6 models also benefit from EPM when the PTO is engaged. Depending on model, EPM makes up to an additional 25hp available.

MF 6600





MF 6600

Transmission	Dyna-4	Dyna-6	Dyna-VT
MF 6612	●		
MF 6613	●	●	
MF 6614		●	●
MF 6615	●	●	●
MF 6616		●	●

The Dyna transmissions

Shift to the transmission that fits your tractor needs

Whether your workload demands a semi-powershift or continuously-variable transmission, MF 6600 tractors can be specified with the format that fits your farm. Dyna-4 and Dyna-6 options offer four and six clutchless shifts respectively, in each of four ranges, which can all be controlled from the armrest joystick or transmission control lever (depending on model). The unique MF Power Control lever on the left side of the steering column provides a PowerShuttle feature, as well as an alternative method of transmission ratio changing and a de-clutch function. Shuttle response can be adjusted according to operator preference.

All Dyna transmissions benefit from:

- Exclusive and straightforward left-hand Power Control lever
- Pedal-free operation, which reduces operator fatigue and makes life easier on the operator
- Plenty of gears in the important 4-12km/h working range, with good overlaps
- Autodrive as standard, taking automatic care of up- and downshifting to maximise versatility and output. Response point is adjustable according to desired engine rpm parameters
- Brake to neutral feature disconnects drive when the brake pedal is pressed
- Shuttle responsiveness can be adjusted according to speed of change required
- Progressive adjustment for Dynashift ratios
- Two optional cruise control speeds (SV1 and SV2 on Efficient and Exclusive version)
- Optional ability to set upper and lower engine speeds



Right-hand T-handle
Simply move the T-shaped transmission control lever forwards or backwards to change up or down through the 4 or 6 Dynashift ratios. To change range, simply press the range selection button as you move the lever.



Simple, multi-function Power Control
The Power Control lever provides convenient three-in-one, straightforward operation. Operators can shuttle between forward/reverse, shift Dynashift speeds and ranges and select neutral, leaving the right hand free to operate the loader or implement hydraulics.

- N** Neutral
- De-clutch
- Forward drive
- Reverse drive
- Change up ratio
- Change down ratio



Dyna-4 – four-speed flexibility



Available on the Essential versions of the MF 6612, MF 6613 and MF 6615, the 16x16 Dyna-4 transmission provides four speeds in each of four ranges, all shifted without any need for the clutch. Creep and super-creep speeds are available as an option.

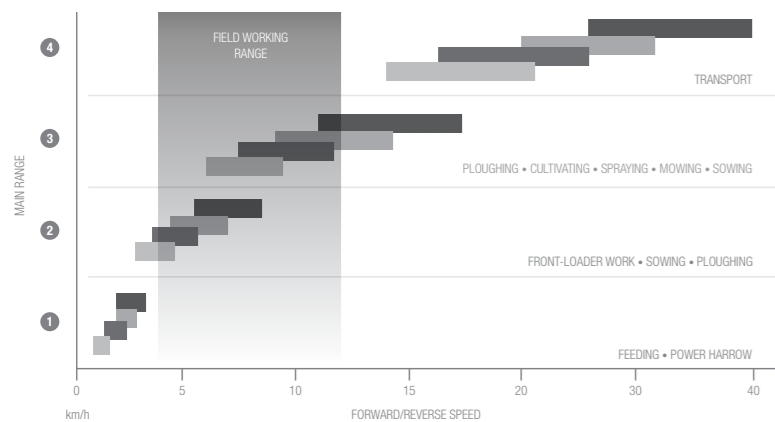

Dyna-4 offers four Dynashift changes in each range with excellent overlaps Field Working range to ensure you can always select the right speed to suit all tasks and conditions. The maximum 40km/hr top speed improves efficiency on the road.

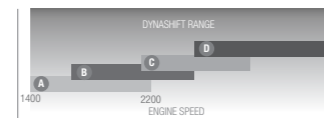

Highlights

Dyna-4 Highlights:

- Exceptional performance in the yard, field or on the road – 16 forward and 16 reverse speeds, all shifted without using the clutch
- Ultimate ease of use with left-hand Power Control lever, T-Lever or Joystick control
- Convenient loader operation, with Comfort Control to set smooth or rapid shuttling
- Select Pedal or Lever mode for optimum comfort and productivity
- Brake pedal puts transmission in neutral

Dyna-6 – performance, refined

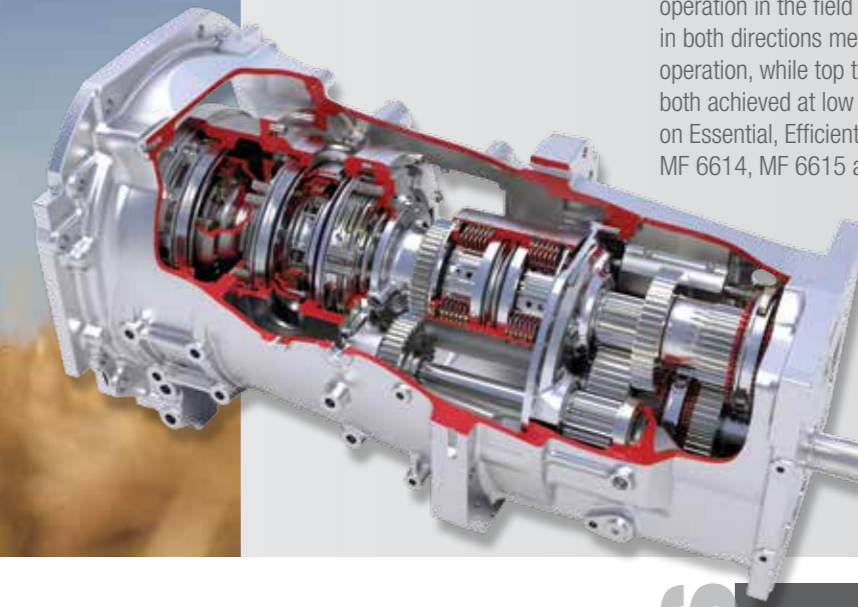

The ultimate in semi-powershift transmissions, Dyna-6 offers six powershift steps in each of four ranges for ease of operation in the field and on the road. A total of 24 speeds in both directions means there's a match for virtually every operation, while top travel speed is either 40 or 50 km/h*, both achieved at low engine speeds. Dyna-6 can be specified on Essential, Efficient and Exclusive versions of the MF 6613, MF 6614, MF 6615 and MF 6616.

* Depending on market/legislation

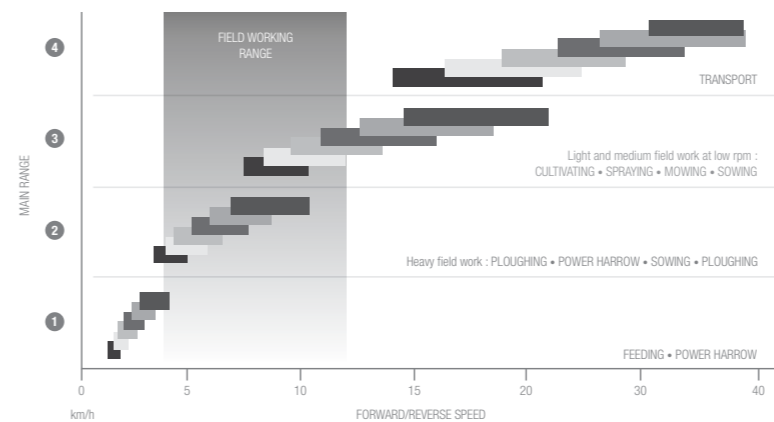

Dyna-6 provides six Dynashift changes in each range provides a 24 forward and 24 reverse speeds, with an excellent overlap and a total of nine speeds in the Field Working range.

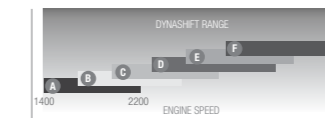

Highlights

Dyna-6 Highlights:

- Maximum productivity with 24 forward and 24 reverse speeds, all shifted without using the clutch
- Power Control lever offers three functions in one – forward/reverse shuttle, declutch and speed shifting
- Nine speeds in the Field Working Range
- Brake pedal puts transmission in neutral
- Creep and Supercreep speeds
- ECO as standard



Dyna-VT

– the tractor transmission without limits

Dynamic performance whatever the application. Massey Ferguson's Dyna-VT transmission provides enhanced productivity in stepless precision.

Highlights

Dyna-VT Highlights:

- 0,03 to 40 km/h or 50 km/h
- 40 km/h super Eco or 50 km/h Eco
- The choice of two speed ranges optimise torque for different applications
- Lever, pedal or automatic control
- SV1/SV2 cruise speeds
- 'Supervisor' maximises the output under varying loads
- Dynamic Tractor Management (DTM) maintains the set travel speed by automatically adjusting the power (engine speed) according to load
- Active Stop
- Turbo clutch on/off
- Shuttle aggressiveness adjustment
- Pedal aggressiveness adjustment
- Switch between cruise speeds (SV1 and SV2)
- Brake pedal to neutral feature

*Depending on market legislation

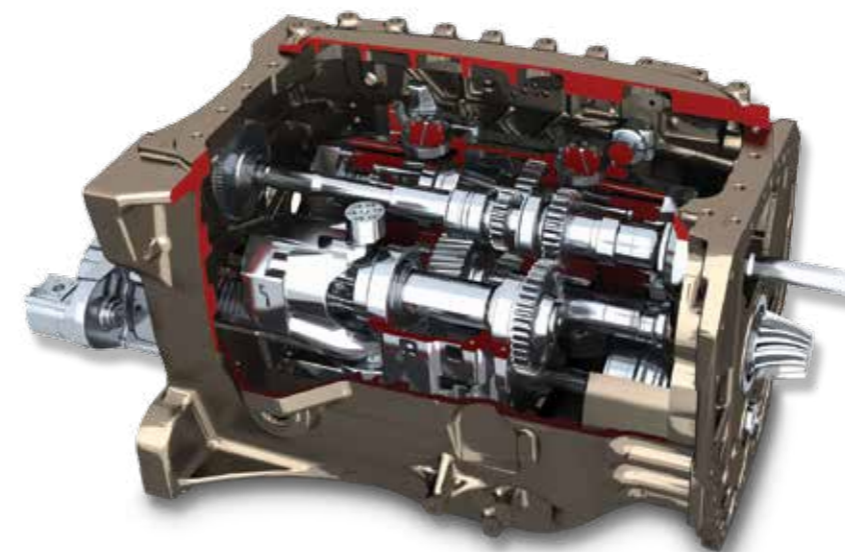

The original Dyna-VT transmission is a true testament to precision engineering; guaranteed productivity, complete operator comfort and optimum fuel efficiency at all times. Further, consistent enhancements such as Dynamic Tractor Management (Dyna-TM) make it the most intuitive transmission on the market.

Stepless precision
Dyna-VT is amazingly simple to operate and works extremely well in differing conditions. There's no shifting of gears, no jolts and no breaks in traction or power. The unique Power Control lever makes forward/reverse shuttling and speed change convenient and hassle-free.

The 'Supervisor'
The 'Supervisor' is on continuous stand-by and activates when engine speed falls under load. The benefit of the 'Supervisor' is that even when the load on the engine is increased and engine speed drops, the transmission will automatically reduce forward speed to maintain total power, whether in PTO applications, field work or transportation.

When used in conjunction with SV1 and SV2, which set a specified forward speed, the tractor will then operate at maximum output as load fluctuates as well as automatically adjusting the tractor back to the required speed.

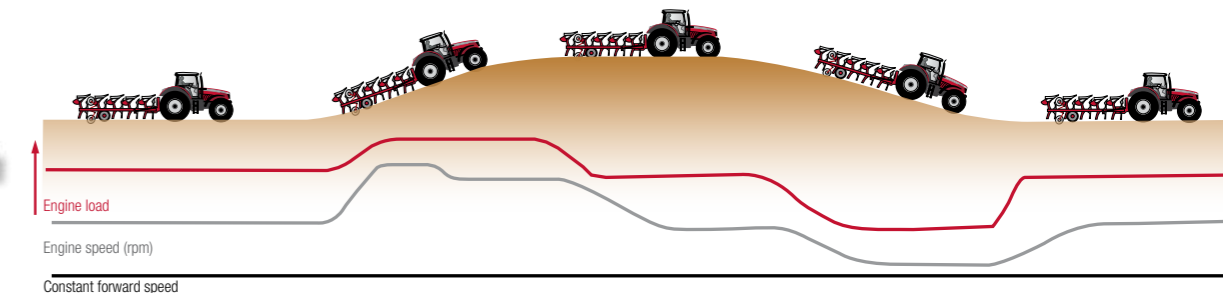

Dynamic Tractor Management (DTM): As the load (red line) varies according to the conditions, the Dyna-VT will automatically adjust the engine speed (grey line) to maintain the forward speed whilst minimising fuel consumption and noise levels.

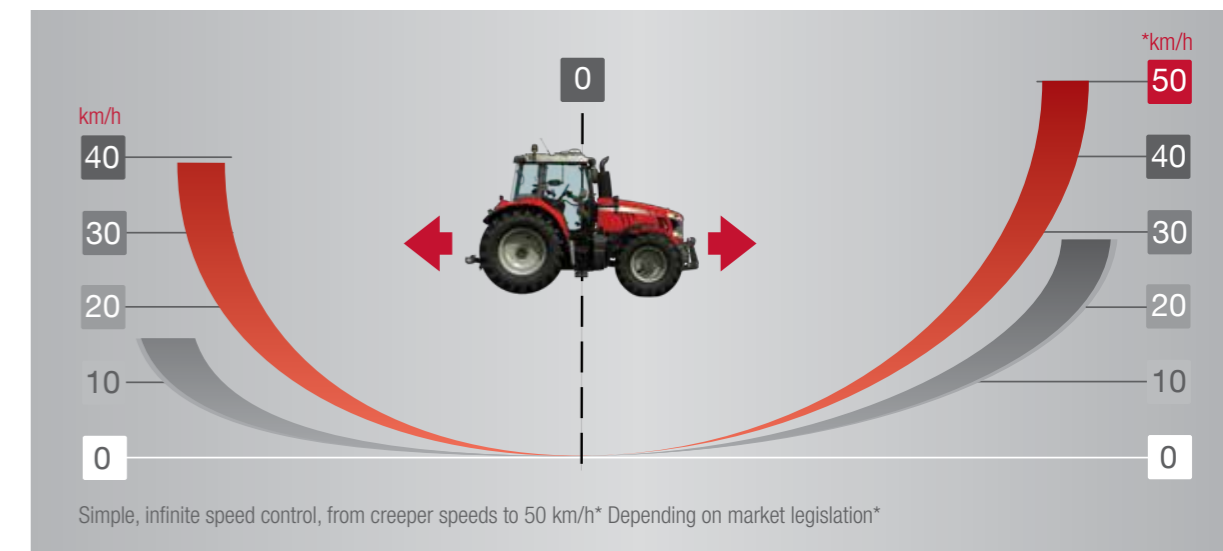

Welcome to a workplace you won't want to leave

Massey Ferguson has long been renowned for the quality of its cabs, and the MF 6600 not only continues but moves a step forward on that tradition. This is a very special working environment – one that blends comfort, quietness, quality and the essence of what Massey Ferguson cabs across our product range are all about. And to enable you to create a working environment that is truly tailored to your needs, there are three cab specification levels from which to choose.

Best in class Ergonomics

Massey Ferguson designers and engineers have listened to farmers feedback to create a cabin where everything you need is exactly where you would expect it. From the information on the comprehensive dashboard to the location of the major controls on the right armrest so that they fall easily to hand, a great deal of thought has gone into the MF 6600 cab interior.

Full efficiency at work

Thoughtful features that boost productivity, save time and generally make tractor operation simpler and easier include everything from easy cab access to 360° visibility, mechanical or Optiride Plus cab suspension and a range of seat options.

Essential, Efficient or Exclusive – your choice

MF 6600 tractors are offered in three specification levels, to give you the freedom to choose the level of comfort and equipment to match your exact needs. Compromise isn't necessary – our aim is simply to help you make a personal choice to match your business requirements and objectives. Everything from engine choice and transmission selection to cab details and equipment can be tailored to suit your planned investment and required needs. There is even a choice of cab roof options, including a standard roof with hatch, Visio roof with visibility panel and falling object protection, for loader work.



Bring Extra Comfort

Two types of cab suspension are available. A mechanical system and the electrohydraulic OptiRide Plus system. Both offer unprecedented levels of cab comfort. The mechanical system uses silent block bushes and spring assisted shock absorbers. The design ensures controlled vertical and lateral movement and provides excellent ride quality. Mechanical cab suspension is active all the time for continuous productivity and comfort. The OptiRide Plus cab suspension system is fully adjustable, allowing the operator to set the firmness of ride using a dial in the cab. Adjustment means the operator can control the ride quality and feel under differing terrain and speed.



More worklights

Early starts and late finishes are no problem thanks to the MF 6600 lighting package, with eight working lights on the cab roof, two on the rear fenders, two on the hand rails and four on the bonnet front. Xenon lighting is available as an option.



Tailor the roof to fit

A choice of roof types allows you to tailor your MF 6600 Series tractor to offer excellent access to buildings and suit your exact needs.



Standard roof with hatch

Visio roof with FOPS

Easy cab access

You can get into the cab through either the left or right doors, with great access up wide, well-spaced steps. The bottom step is fully-adjustable so you can choose the most convenient, comfortable height.

MF 6600



Essential

The new standard for straightforward operation



Essential is the base specification for the MF 6600 Series, but it is anything but basic. It provides all the key elements you would expect from Massey Ferguson, with a blend of simplicity, easy to use and versatility to fit needs that require power and performance without excess sophistication.

The right hand console on Essential models features a T-bar transmission controller, hand throttle and linkage control.

Essential specification tractors are also available with a multifunction loader joystick, which works seamlessly with the fully-compatible range of Massey Ferguson loaders.

The right hand side console and B-Pillar contain all of the tractors' key operating controls. The pillar contains less frequently-used switches, working light controls and the ignition key, while the console is home to spool valve and PTO controls. The console also houses the transmission lever, hand throttle and electronic linkage controls.



Worklights and beacons control panels

Electronic rear linkage adjustment

Up to four lockable spool valves can be specified as an option

Transmission control lever for effortless speed and range changes

Hand throttle

Electronic linkage control

Linkage depth control



Essential cab control with loader joystick

Massey Ferguson's unique mechanically-controlled multi-function joystick, which is integrated into the right-hand console, can be specified for Essential tractors. Specifically designed for use with MF loaders, its design ensures smooth operation and allows the use of transmission functions such as forward / reverse selection.

Standard Essential features include:

- Control Centre with T-handle transmission lever
- Dyna-4 or Dyna-6 - 40 km/h Eco with Autodrive
- Clutch Effect
- Air conditioning with manual adjustment
- Mechanical control of spool valves

Essential specification options:

- Dyna-6 50 km/h Eco transmission*
- Quadlink suspended front axle
- Mechanical cab suspension
- loader ready from factory with Multifunction mechanical joystick
- Closed Centre Load Sensing hydraulics
- AGCOMMAND™ Ready
- Panoramic cab with polycarbonate right-hand side window

* Depending on market/legislation

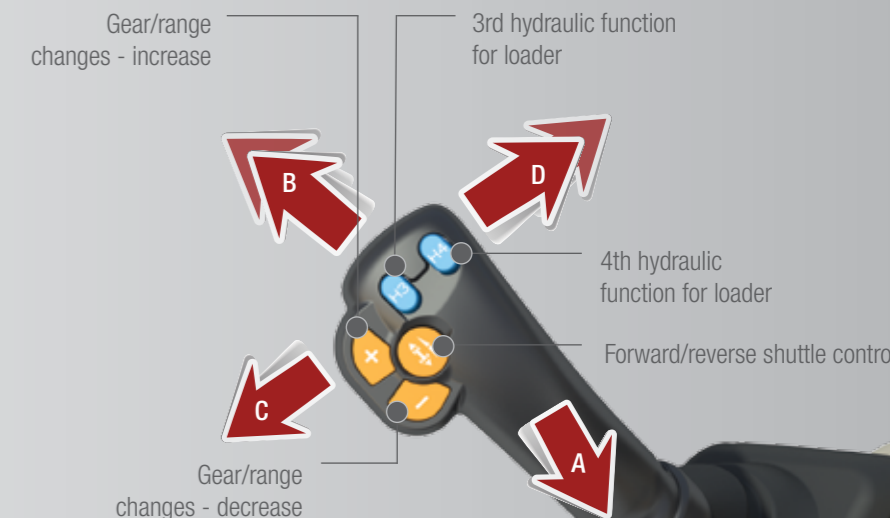

Front and rear PTO switches and Auto PTO function

Mechanically controlled Multi-function joystick

Engine management: engine lower and upper limit engagement

Autodrive function

Hand throttle



'Multifunction' joystick main functions:

- A. Lift
- B. Lower
- C. Fill
- D. Dump

Combined functions:

- A/C. Lift and fill
- A/D. Lift and dump
- B/C. Lower and fill
- B/D. Lower and dump

Efficient

Advanced equipment to boost work accuracy



Efficient is the medium specification package for the MF 6600 Series. Choose from either Dyna-6 or Dyna-VT transmissions, a new Command Control Armrest and both mechanical and electronic spool valves.

Dedicated to delivering increased productivity thanks to key features. The Efficient specification will enable the operator to work faster, to a higher standard, with more accuracy together with high levels of comfort, ergonomics and reliability.

Standard Efficient features include:

- Dyna-6 Autodrive or Dyna-VT 40 km/h Eco transmission
- Command Control Armrest with T-Lever
- Cruise speed control and Clutch Effect
- Quadlink front axle
- Closed Centre 110 l/min hydraulics
- Electrical and mechanical spool valves
- Standard Air Conditioning
- Mechanical Cab suspension

Efficient specification options:

- 50 km/h Eco Dyna-6 and Dyna-VT
- OptiRide Plus cab suspension
- Integrated front linkage and PTO
- Automatic Air Conditioning
- Datatronic 4 CCD
- Loader ready from factory with Multifunction electrical joystick
- AGCOMMAND™ Ready
- Auto-Guide™ 3000
- Full Auto-Guide™ 3000 available

* depending on market/legislation



Worklights and beacons control panels

Electronic rear linkage adjustment

Up to four lockable spool valves can be specified as an option

Transmission control lever for effortless speed and range changes

Electronic linkage control

Linkage depth control

Hand throttle



Efficient cab control with optional loader joystick

Datatronic control centre display

An option on Efficient tractors and standard on Exclusive models, the Datatronic 4 control centre display (CCD) has a perfectly-positioned 7" colour monitor mounted to the operator's right, and fully adjustable to meet eye level. The CCD displays important tractor information, records and shows memory functions and tasks, and oversees automation of headland management, trailed implement control (TIC) and Dual Control. The CCD has ISOBUS capability and can be connected to a camera for improved vision on rear mounted implements and trailers



Travel speed increase (Dyna-VT) or gear change up (Dyna-6)

Travel speed decrease (Dyna-VT) or gear change down (Dyna-6)

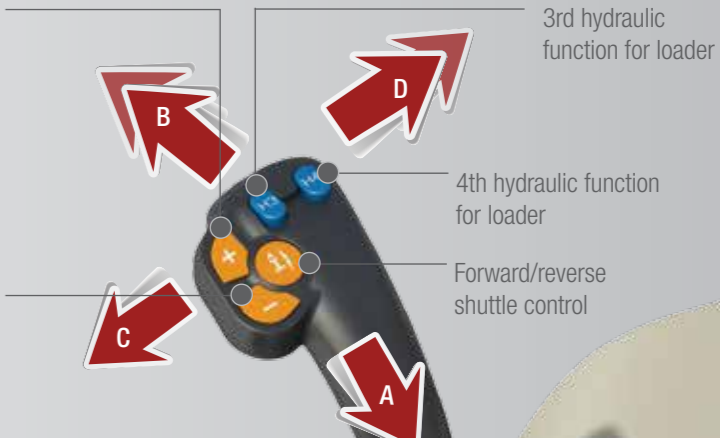

'Multifunction' joystick main functions:

- A. Lift
- B. Lower
- C. Fill
- D. Dump

Combined functions:

- A/C. Lift and fill
- A/D. Lift and dump
- B/C. Lower and fill
- B/D. Lower and dump



3rd hydraulic function for loader

4th hydraulic function for loader

Forward/reverse shuttle control

Exclusive Package

The ultimate expression of productivity and innovation



Exclusive is a combination of high-spec versatility and refinement dedicated to customers looking for a tractor with advanced features and functions in terms of ergonomics, comfort and automation.

The package is aimed at the more intensive, large scale operators looking for more advanced features that will ensure cost effective benefits for their business.

The Exclusive armrest comes with numerous benefits including comfort and convenience when operating numerous, frequently used controls.

Standard Exclusive features include:

- Command Control Armrest with Multipad lever
- Dyna-6 Autodrive or Dyna-VT 40kph Eco transmission
- Cruise speed control and Clutch Effect
- Quadlink front axle
- Closed Centre 110 l/min hydraulics
- 4 electronic spool valves with fingertip controls
- OptiRide Plus cab suspension
- Automatic Air Conditioning
- Datatronic 4 CCD with ISOBUS and camera provision
- Dual Control and Headland Management System
- AGCOMMAND™ Ready

Exclusive specification options:

- 50 km/h Eco Dyna-6 and Dyna-VT*
- Air Brakes
- Integrated front linkage and front PTO
- SpeedSteer
- Loader ready from factory with Multifunction electrical joystick
- Auto-Guide™ 3000 Ready
- Full Auto-Guide™ 3000 available

* depending on market/legislation



Exclusive cab controls with loader joystick

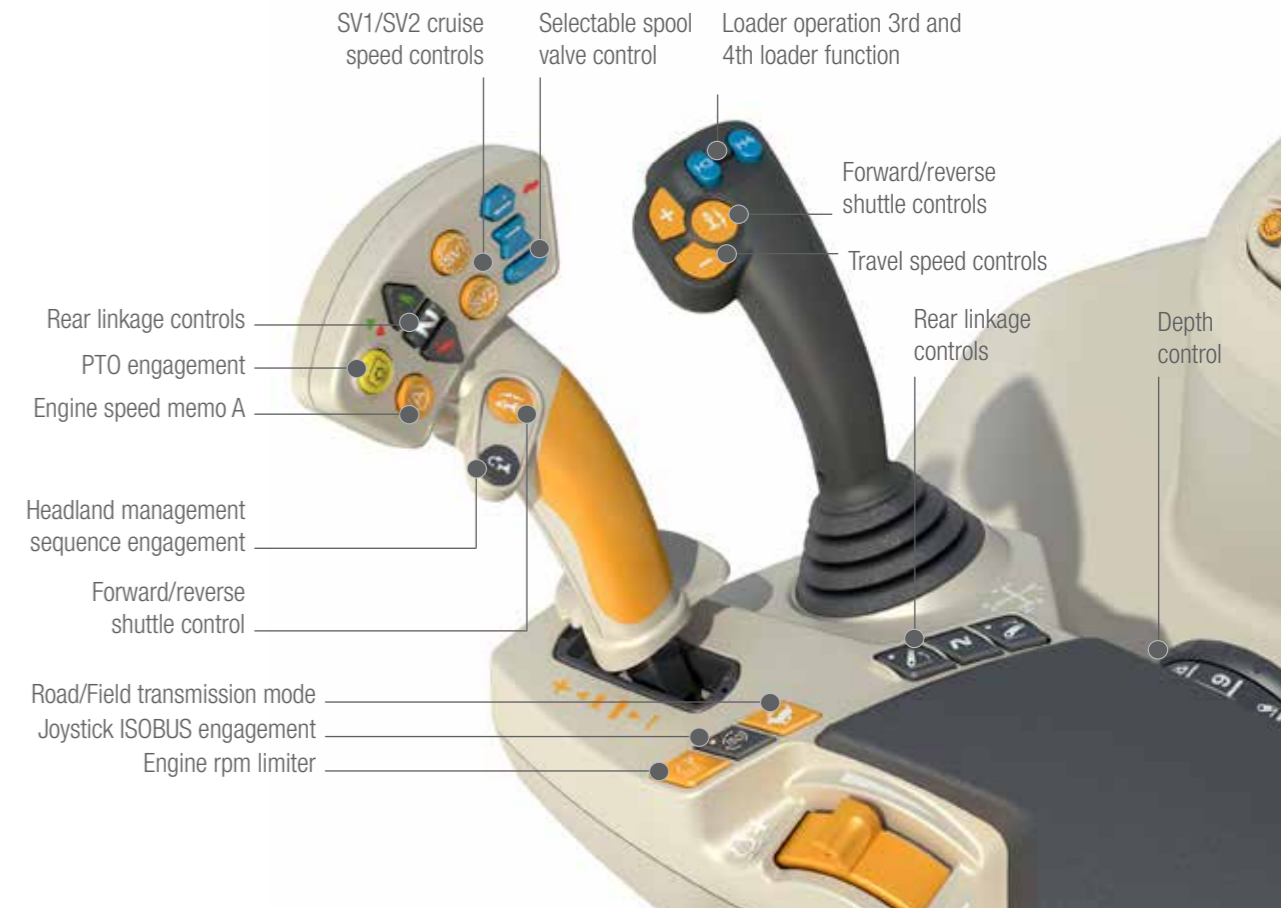

The Essential Panoramic cab option



The MF 6600 Series Panoramic cab offers unobstructed visibility to the right hand side for safe and efficient operation of side-mounted equipment. The wide, one-piece polycarbonate screen is extremely tough and protects operators from flying debris.

A special anti-scratch coating and dedicated wash/wipe system maintains great visibility in all conditions. For local authority and road work operations the cab can be equipped with fixing brackets and wiring for hazard warning lights and signs.

If you want to find out more about the Massey Ferguson Panoramic cab tractors and their outstanding features, don't hesitate to ask your local MF Dealer or Distributor. Pick-up a copy of our dedicated brochure.



Operate your loader the Massey Ferguson way

When you purchase a Massey Ferguson loader with your new MF 6600 tractor, whether you have ordered it Essential, Efficient or Exclusive specification, it can be specified fully loader-ready to accept an MF loader. Your tractor will come complete from the factory with the loader subframe, designed for maximum manoeuvrability and maintenance access, already built on so that it forms an integral part of the machine.

The optional mechanical multifunction joystick has additional transmission functions such as forward/reverse and speed change for added versatility during operation.

You will enjoy superb visibility thanks to slim bonnet and dash profiles. The optional Visioline roof improves vision of loads at height, and is particularly useful when stacking bales, for example.

The new 'clutch effect' feature built into Massey Ferguson's latest braking systems puts the transmission into neutral when the brake pedals are depressed, allowing single-foot brake and clutch operation and making loader operation safer, easier and a lot more comfortable.



▲ Visioline roof with FOPS



The Active stop (Dyna-VT) or the Neutral (Dyna-4 and 6) switch is located at the back of the Multifunction joystick

Highlights

Tractor/Loader combination highlights :

- A flexible range for a wide variety of applications
- Optional multifunction joystick comes with forward/reverse and speed change for added versatility
- Highest visibility thanks to the smart design of the bonnet and the dashboard
- Factory fitted loader subframe for optimum performance of your all-purpose tractor
- Optimum manoeuvrability and access to maintenance operation
- Optional Visioline roof with Falling Object Protection (FOPS)
- Excellent manoeuvrability including tight turning angles, SpeedSteer and rapid response from engine and hydraulics



Loader operation

'Mechanical Multifunction' joystick main functions:

- A. Lift
- B. Lower
- C. Fill
- D. Dump

Combined functions:

- A/C. Lift and fill
- A/D. Lift and dump
- B/C. Lower and fill
- B/D. Lower and dump - bucket adjustment to horizontal position

“The beauty of this joystick means you can go from forward to reverse and operate the loader at the same time, without taking your hand off the steering wheel.”

MF 6600

MF 6600	MF 900 Series loaders without parallel linkage		MF 900 Series loaders with parallel linkage			
	MF 931	MF 961	MF 956	MF 958	MF 966	
Lift height to pivot pin	●	●	●	●	●	
Lift height to pivot pin	m	4.0	3.50	4.0	4.0	4.25
Lift capacity at max. height at pivot pin	Kg	2310	2060	2060	2370	2440
Lift capacity ground level at pivot pin	Kg	2920	2690	2520	2890	2790
Min rollback angle	Degrees	45	44	45	45	45
Max dump angle	Degrees	55	58	55	55	52
Digging depth	mm	165	155	160	160	170

Best in Class Manoeuvrability and traction

The MF 6600 curved chassis and bonnet smart design helps these tractors turn as tight as anything on the market. Chassis design is such that the tractor handles well on the road, and has perfect weight distribution for excellent traction yet minimal soil impact in the field in all applications.



Quadlink front axle suspension brings comfort

The Quadlink system, which can be switched on and off, uses hydraulic accumulators acting on the front axle to dampen ride over rough roads and fields, and improve comfort and safety on transport applications. It features a unique parallelogram linkage that provides 90mm of suspension travel and is controlled by a single, well-protected hydraulic ram mounted within the axle housing. An automatic control system ensures equal suspension movement in both compression and extension.

Tight turning circle

Whether in the field or around the yard, the turning circle benefits of the short wheelbase and curved front frame design that MF engineers have incorporated into the MF 6600 soon become apparent. Even on tractors specified with a front linkage, this is not compromised. The MF 6600 tractors can turn in a circle just 9.8 m in diameter. That means faster headland turns, quicker loader work and a more productive man and machine.

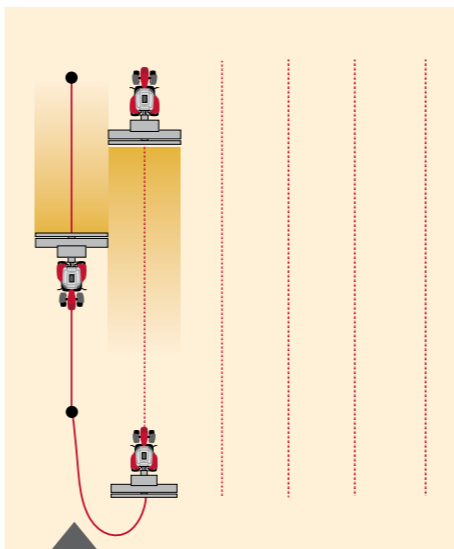

SpeedSteer: faster, easier headland turns

New, optional SpeedSteer reduces the operator effort required for steering and provides faster headland turns, by allowing the operator to adjust the steering ratio and select the number of steering wheel turns required for a given amount of steering angle. The system can be switched on and off – above 18km/h it is automatically turned off for safety reasons. As well as being handy in the field, SpeedSteer is also ideal for loader work.

Wheelbase - traction and soil preservation

Massey Ferguson designers have sought to provide the MF 6600 tractors with the perfect chassis size for the wide range of tasks of which they are capable. That means better handling off road and on, during field tasks and haulage. It also means minimum ground pressure and soil damage when working on the land, while a short wheelbase and perfect power-to-weight ratio mean excellent manoeuvrability when making headland turns. That's part of our commitment to help protect the soil and preserve the land for future generations.

Four-wheel drive and differential lock

Massey Ferguson has long been known for making tractor operators' lives easier and maximising traction, safety and productivity through automation, and the MF 6600 Series takes that a step further. Automated functions on the differential lock and 4WD systems include:

- Automatic disengagement of 4WD and differential lock above 14km/hr
- Automatic differential lock disengagement when a rear linkage-mounted implement is raised (and re-engagement when lowered)
- Automatic differential lock disengagement when either one or both of the brake pedals are pressed (and re-engagement when released)
- Automatic 4WD engagement when both brake pedals are depressed, when the differential lock is engaged or the handbrake applied
- Automatic diff lock activation linked to wheels turning angle



Power and performance to tackle any task

The MF 6600 has been designed to come with immense capabilities and to easily handle heavy-duty applications with outstanding lift and drive capacities for the very latest implements.

Wide choice of PTO options

A full range of standard and economy PTO speeds can be specified for MF 6600 Series tractors. The PTO driveline is directly taken from the engine flywheel to the independent PTO clutch, before being transferred through the speed selection gears to the output shaft. This simple drive layout minimises power losses for maximum productivity and efficiency. An auto PTO feature engages and disengages the rear PTO according to front linkage position.

All speeds are selected from the operator's seat or, on standard spec tractors, at the rear of the machine. The 540 and 1,000rpm PTO speeds occur at close to

1,900/2,000 engine rpm, while maximum engine power peaks at 1,950rpm. Economy 540 and 1,000rpm PTO speeds are reached at 1,550 engine rpm, depending on model. Ground speed PTO is also provided. The MF 6600 tractors are also available from the factory with a front PTO that uses a 1,000rpm six-spline shaft.

Highly-specified three-point linkage

Massey Ferguson has always led the way in electronic linkage design – and continues to do so. Part of Massey Ferguson DNA, our three-point linkage is the finest example of productivity, power and responsiveness for the operator in the field for more than 75 years. All MF 6600 tractors feature heavy-duty Cat II/III rear linkages with quick couplers. A pair of externally-mounted lift cylinders are fitted with the cylinder mounted uppermost to prevent the ingress of dust or water.

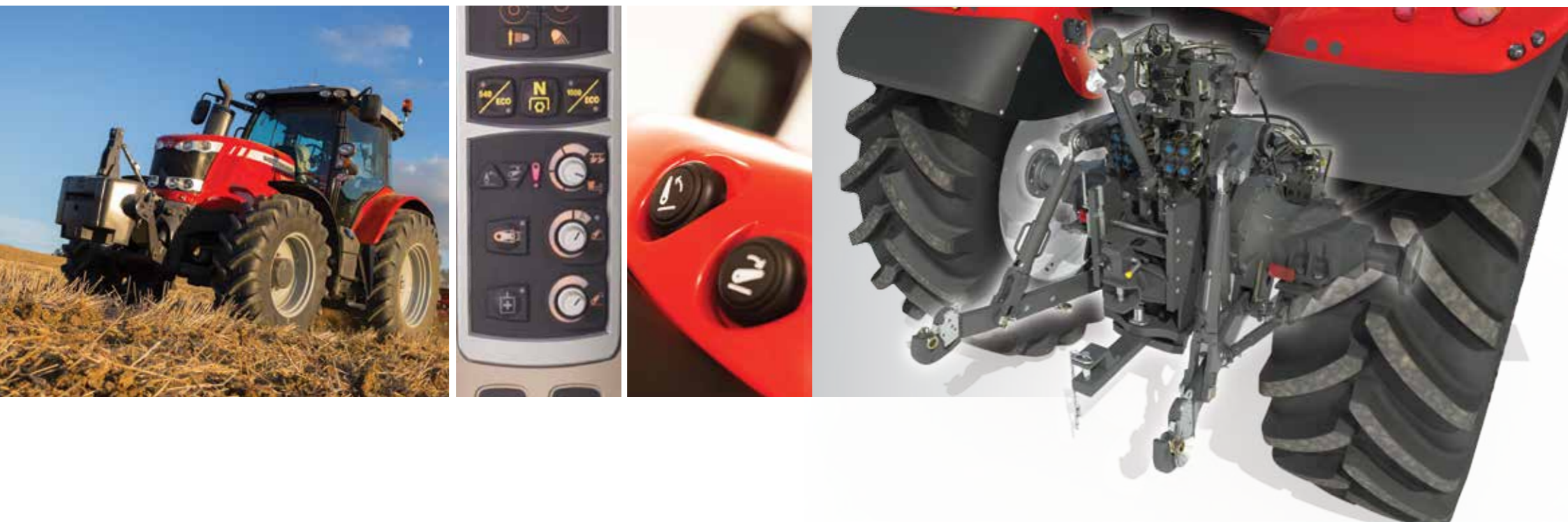

Lift capacity

Dyna-4 tractors	7,100kg
Dyna-6 tractors	7,100kg (8,100kg option for MF 6615/MF 6616 Efficient/Exclusive)
Dyna-VT tractors	8,600kg

Electronic linkage control (ELC) management is via the console or armrest-mounted ELC controls. While this controls immediate linkage functions such as the lift/lower switch and the working depth/height wheel, the controls on the right-hand console allows precision setting of position/intermix/draft control, quick soil engagement, rate of drop, maximum lift height, working depth/height control, lift/lower control and Active Transport Control.

The separate linkage settings panel allows the setting of position/intermix/draft control, as well as rate of lowering.

Accurate draft control

Massey Ferguson's digital ELC system gives the highest standards of draft control with more accurate depth settings and better ground contour following. The result is more weight transfer, better traction, less wheelslip, reduced tyre wear and reduced fuel consumption whilst still maintaining greater output.



Oil flow to power the most demanding implements

Massey Ferguson recognises that modern implements are placing more and more demands upon the tractors asked to power them. Not only that, but with tractors themselves asked to perform faster and sharper, response in areas such as hydraulic clutch packs, steering and brakes has had to keep pace. Our engineers have responded with three hydraulic system choices for MF 6600 tractors:



- **Standard open centre 58 litres/min unit.** This uses a high pressure pump to provide 58 litres/min to the rear spool valves and linkage, while a separate low pressure 42 litres/min supplies the tractor's steering, powershuttle, transmission, PTO and 4WD/diff lock
- **New open centre 100 litres/min combined flow option.** This system uses three gear pumps. A low pressure gear pump on the left of the tractor services the internal systems, while a pair of high pressure gear pumps are sited on the tractor's right. One supplies 58 litres/min to the rear linkage, while the second 42 litres/min unit supplies the auxiliary valve. The flow from these pumps can be combined by an automatic valve and operated from a cab switch, to lock out the rear linkage and provide 100 litres/min for the auxiliary valves or front loader operation
- **A closed-centre, load-sensing high-flow 110 litres/min system** for faster hydraulic response. This uses a variable displacement swash plate pump in addition to the load-sensing system found above. High flow at low engine speeds maintains high output with economy, as the variable flow pump only supplies oil on demand, while the full output of the large capacity pump is only put into action when required

MF 6600



Version	Dyna-4	Open centre system		Closed centre system
	Transmission	58 l/min	100 l/min	110 l/min
Essential	Dyna-4 and Dyna-6	●	○	○
Efficient	Dyna-6 and Dyna-VT	-	-	●
Exclusive	Dyna-6 and Dyna-VT	-	-	●

- Not available ● Standard specification ○ Optional

All Fused with Straightforward On-Board Technologies



The on-board technology solutions incorporated into the MF 6600 Series are a clear indication of the pace of progress and innovation setting by Massey Ferguson. Information is power when it comes to get the job done more efficiently and more productively. This is the reason why, Massey Ferguson delivers straightforward and dependable technology solutions resulting in unbeatable ease of use, improved productivity and profitability through higher yields, lower inputs costs and greater profits.



AGCO's overarching new technology strategy is called Fuse Technologies and it will provide professional growers around the globe seamless integration and connectivity across all their farm assets. It will transform farming by delivering precision agriculture solutions that lead to reduced input costs, greater efficiency and profitability.

The CCD console.

Keeping you informed and in control



1
Full tractor functions management and optimisation features (transmissions, engine and hydraulics).



2
Video Mode – Pictures from an on-board camera can be displayed on the console screen, allowing operators to monitor complex implements or simply improve safety and efficiency when reversing.



3
ISOBUS for total implement control – ISOBUS allows an implement manufacturer's control system to be displayed on the console screen, saving owners and operators time and money, with no need to install additional terminals in the cab. Simply plug the implement lead into the tractor's ISOBUS socket and the system automatically uploads the operating menus and displays on the screen – implement control switch assignment on Multipad available (exclusive version only).



Fitted as standard on MF 6600 Exclusive models, and available as an option on Efficient models, the CCD console puts information at your fingertips to allow you to quickly make the best decisions to run your business efficiently.

4
Auto-Guide™ 3000 auto-steering guidance operation can be displayed through the CCD rather than through a separate screen, providing the driver with enhanced visibility. Thanks to this integration, no additional wires are needed – refer to p.44 guidance section to find out more about the most easy-to-use guidance system available in the market today.



5
Memorise data and settings – Up to eight different memories enable the system to record information during operation on area worked, fuel use, hours worked and much more. All the settings and parameters can be stored by the CCD Securely back-up those tractor settings: A truly unique feature of CCD is the ability to save the memorised tractor settings to a USB memory stick and manage those settings before commencing work. All these settings can be transferred between all your machines equipped with CCD.



6
Headland management settings – The CCD Console comes as standard with the most intuitive, straightforward and easy to use automatic headland management system available in the market today and developed exclusively by Massey Ferguson. It is designed to save you significant time at headlands, allowing you to concentrate on the operation in hand so that you can maximise outputs with ease.



Straightforward and intuitive technology From Massey Ferguson



Guidance options to keep you on track for profit

With guidance systems having been proven to save up to 12% fuel in field operations, more and more farmers are considering the benefits of investing in guidance and auto-steering. Auto-Guide™ 3000 is a hands-free steering system that is capable of delivering sub-metre, decimetre and centimetre accuracy.

An Auto-Guide™ 3000 TopDock receiver comes factory-fitted as an option to Efficient and Exclusive MF 6600 tractors. This allows the use of the free sub-metre accuracy EGNOS correction signal. Upgrades are made easily, without unlocking code, by only adding a snap-in module to the base of the TopDock. An inertial measurement unit (IMU) can be installed to improve tractor positioning where greater accuracy is required, with a radio snap-in providing the ultimate in precision.



Datatronic CCD console

Auto-Guide™ 3000 can be displayed through the Datatronic CCD for those who need a simple and integrated guidance terminal, rather than through a separate screen, this allows increased visibility for the driver. The optional C3000 terminal, available via AGCO Parts, offers advanced capabilities and allows you to achieve more. It's the ideal solution for anyone wanting to keep a constant record of job and tasks.



Guidance patterns

Auto-Guide™ 3000 allows you to create and follow the most efficient and practical guidance patterns.

Accuracy	30 cm	20 cm - 5 cm	2 cm
Correction signal	EGNOS* OmniSTAR VBS	OmniSTAR VBS/HP OmniSTAR G2	RTK Base station NTrip
Receiver	Auto-Guide™ 3000 TopDock	Auto-Guide™ 3000 TopDock with IMU	Auto-Guide™ 3000 TopDock with IMU and Radio snap-in
Applications	Spraying/spreading Harvesting Cultivation Mapping	Spraying/spreading Harvesting Cultivation Mapping	Seeding/planting Strip tillage Weeding

GO MODE FUNCTION

A Go mode function allows the operator to begin working with auto-guidance/steering for the first time within a five-minute set-up time, making the system easy to work with and the benefits faster to reap.

This is the easiest way to start auto-guidance without going into any settings, and suits those looking for a simple system to use that does not require advanced settings.

This unique function allows Auto-Guide™ 3000 start-up within 5 minutes to allow even inexperienced drivers to step seamlessly into working with the system after just a few implement and wayline settings.



AGCOMMAND™ puts your finger on the pulse at all times

AGCOMMAND™ is the perfect fleet management and monitoring tool for large businesses, contractors or anybody who needs to keep a close eye on equipment out working – at all times. Part of the Fuse Technologies, it can be fitted to a wide range of equipment to create a comprehensive, universal system.

Operating data is collected automatically, transferred wirelessly and displayed in near real time on a secure webpage – there's no need to install any special software.

On the go flexibility

Take all the benefits of AGCOMMAND™ to the field with the new AGCOMMAND™ app, for iPads and iPhones, allowing you to monitor machinery information, as remaining fuel level, wherever you are and whenever you want. You can also use the history and efficiency report functions and analyse equipment in the field.

The app offers all the same functions as the desktop version including the same near real time access to the machine homepage that supplies information fast and a quick overview of machine data – position, address and weather.



Scan me to get the app!



Home page



Machine details



History reports



Efficiency reports



Servicing made easy

With an MF 6600 Series tractor, routine maintenance is fast, straightforward and simple – in short, less stressful. That means you don't waste time in the mornings, and get out of the yard and into the field faster.

Service intervals have been increased by 25% to 500 hours, substantially cutting maintenance costs.

improved access to remove the cab air filter for cleaning.



Front axle and slim waist bonnet design make oil dipstick and filter access easy.



Engine air filter is easy to access and clean. Up to 90% of dust is removed by the suction system from the exhaust gas.



Radiators flip out for cleaning, and can be easily accessed with an air line.



Single-piece bonnet lifts fully for easy access

Total Support. There when you need it

The Massey Ferguson distributor and dealer network ensures every machine comes with the support and service you need to keep working – whenever and wherever you need it.

Our dealers are committed to finding the right product for you and then supporting you with the best services, parts provision and back-up. Behind every Massey Ferguson machine is a family of highly skilled specialists who are dedicated to supporting you, your equipment and your business.

Ask your dealer about our finance plans, which can include leasing, hire purchase, contract hire and loan facilities.

manager provides total peace of mind

manager Service and Extended Warranty Plan* is a comprehensive, industry-leading package that provides total care of your tractor providing routine maintenance, repairs and a full AGCO-backed warranty, which includes:

- Engine and transmission
- Hydraulics
- PTO
- Steering
- Electronics
- Cab and controls
- Axles

Regular servicing in the **manager** plan provides 'preventive maintenance' – picking up any faults before they become a problem, which helps reduce downtime. A full dealer service history, using genuine AGCO Parts will also increase the residual value of the machine.



Industry-leading parts supply from AGCO Parts.

Standard and optional equipment by cab type

	Essential	Efficient	Exclusive
Engine			
AGCO POWER 4 Cylinder Stage 3b	●	●	●
Selective Catalytic Reduction (SCR) technology Generation 2	●	●	●
Extra Idle Engine Speed	●	●	●
Transmission			
Power shuttle control	●	●	●
Right-hand shuttle	○	○	○
T-lever on Control Centre	●	-	-
T-lever on Command Control Armrest	-	●	-
MultiPad on Command Control Armrest	-	-	●
Dyna-4 - 40 km/h - Speedmatching and Autodrive	●	-	-
Dyna-6 - 40 km/h Eco - Speedmatching and Autodrive	○	●	●
Dyna-6 - 50 km/h** Eco - Speedmatching and Autodrive	○	○	○
Supercreeper or creeper	○	○	○
Dyna-VT 40 km/h Super Eco with Dynamic Tractor Management (DTM)	-	○	○
Dyna-VT 50 km/h** Eco with Dynamic Tractor Management (DTM)	-	○	○
Cruise speed control	-	●	●
Brake to neutral - Clutch effect	●	●	●
Operator environment			
Standard air conditioning with manual adjustment	●	●	-
Automatic Air Conditioning/climate control	-	○	●
Cool box	●	●	●
Air suspended swivel seat	●	●	-
Automatic air suspended dynamic damping system seat	-	○	●
Auxiliary Seat with Seatbelt	●	●	●
Radio Pre-wired	●	-	-
Radio - MP3 - SD card slot - USB	○	●	-
Radio - CD -MP3 - Equalizer, bluetooth, USB and front aux	-	○	●
Telescopic Large Side Mirrors	●	●	-
Telescopic Large Side Mirrors with Electric Adjustment and de-icing	-	○	●
2 opening doors	●	●	●
Mechanical Cab Suspension	○	●	-
OptiRide Plus Cab Suspension semi-active	-	○	●
Visio roof	○	○	○
Roof hatch	○	○	○
Radar and slip control	○	○	●
CCD/Datatronic 4 with video and isobus capability	-	○	●

- Not available ● Standard specification ○ Optional ** Depending on market legislation

Whichever sector you're in, make the tractor your own...

	Essential	Efficient	Exclusive
Operator environment			
Trailer steering axle management	-	○	○
Dual Control	-	○	●
Headland Management System	-	○	●
Speedsteer	-	○	○
Panoramic cab with polycarbon right-hand side window	○	-	-
Technology			
Auto-Guide™ 3000 Ready	-	○	○
Auto-Guide™ 3000	-	○	○
AGCOMMAND™ Ready	○	○	●
Chassis and hydraulics			
Mechanical controls of spool valves	●	-	-
Electrical and mechanical controls of spool valves	-	●	-
Electrical controls of spool valves	-	○	●
Multifunction joystick	-	○	○
Loader ready tractor with Multifunction joystick (Mechanical control)	○	-	-
Loader ready tractor with Multifunction joystick (Electrical control)	-	○	○
Electronic linkage controls with Active Transport Control	●	●	●
Power Beyond	-	○	●
Auto PTO function	●	●	●
Electric PTO speeds selection	○	○	○
Auto 4-Wheel Drive and Auto Differential lock functions	●	●	●
Telescopic stabilisers	●	●	●
Automatic stabilisers	○	○	○
Integrated front linkage system	○	○	○
Integrated Front PTO	○	○	○
Electrical equipment			
Automatic Isolator switch	●	●	●
ISO signal connector	-	●	●
External lift control on fenders	●	●	●
External PTO start/stop control on fender	●	●	●
Xenon lighting	○	○	○
Other equipment (Specifications may vary by market)			
Quadlink - Suspended front axle	○	○	●
Pivoting front fenders	○	○	●
Additional in-cab heater	○	○	○
Hydraulic trailer brake	○	○	○
Pneumatic trailer brake	○	○	○

Every effort has been made to ensure that the information contained in this publication is as accurate and current as possible. However, inaccuracies, errors or omissions may occur and details of the specifications may be changed at any time without notice. Therefore, all specifications should be confirmed with your Massey Ferguson Dealer or Distributor prior to any purchase.

Specifications as standard

Engine	MF 6612 Dyna-4	MF 6613 Dyna-4	MF 6615 Dyna-4	MF 6613 Dyna-6	MF 6614 Dyna-6	MF 6615 Dyna-6	MF 6616 Dyna-6	MF 6614 Dyna-VT	MF 6615 Dyna-VT	MF 6616 Dyna-VT
Type	AGCO POWER with 2nd Generation SCR									
no. of cylinders/no. of valves/Capacity - litre/ no./ cm3	4/ 4/ 4900									
Aspiration	Turbo Intercooled									
Injection type	Common rail									
Fan type	Viscostatic	Viscostatic	Viscostatic	Vistronic	Vistronic	Vistronic	Vistronic	Vistronic	Vistronic	Vistronic
Maximum hp (ISO 14396) hp (kW) @ 1950 rpm	120 (88)	130 (96)	145 (107)	125 (92)	140 (103)	150 (110)	160 (118)	140 (103)	150 (110)	160 (118)
Maximum torque (Nm) @ 1500 rpm	511	553	652	553	645	660	677	645	660	677
Maximum power with EPM hp	135	145	160	150	165	175	185	-	-	-
Maximum torque with EPM Nm	575	618	670	648	691	745	790	-	-	-
Max. power available @ PTO shaft (OECD, accuracy +/- 3%)	105	115	125	110	125	135	140	120	130	140
Fuel tank capacity - litres	250									
AdBlue® tank capacity - litres	30									
Service interval - hours	500									
Transmission										
Type	Dyna-4 40 km/h-Semi-powershift			Dyna-6 40 km/h Eco or 50 km/h** Eco				Dyna-VT		
Number of gears - Fwd x Rev	16x16			24x24				Stepless, continuously variable transmission with Dynamic tractor management		
Min. speed @ 1400 rpm km/h	1.3			1.03				0.03		
No of speeds with creeper/supercreeper - Fwd x Rev	24 x 24 / 32 x 32			36x36/ 48x48				-		
Min. speed @ 1400 rpm with creeper/ supercreeper km/h	0,33 / 0,09			0,26/0,07				-		
40 km/h Eco at engine speed - rpm	-			1800				1500		
50 kh/h** Eco at engine speed - rpm	-			1950				1875		
Dyna VT speed ranges										
Field speed range	-			-				0,03 - 28 Kph Forward and 0,03 - 16 Kph Reverse		
Road speed range	-			-				0,03 - 50 Kph* Forward and 0,03 - 38 Kph Reverse		
Rear Linkage and hydraulics										
Lower links type	Category 3									
Maximum lift capacity, at link end	7100			7100		7100/8100		8600		
Hydraulic type	Open centre (Essential)					Closed Centre Load Sensing				
Maximum flow - rpm	58 l/mn supplying spool valves and linkage					110 l/mn				
Maximum pressure - bars	200									
Maximum no. of rear spool valves	4									
Hydraulic type - Option 1	Combined flow : 58 l/mn supplying rear linkage + 42 l/mn supplying spool valve (Essential). The two pumps can be combined to supply 100 l/min to spool valves (including loader)									
Hydraulic type Option 2	Closed Centre Load Sensing									
Maximum Flow - litres/min	110									

** Depending on market legislation

Power Take-Off (Rear)
540/1000 Dyna-4 & Dyna-6 - rpm
540/540Eco/1000 Dyna - VT - rpm
540/540Eco/1000/1000Eco - rpm
Shaft diameter - inches
Front linkage and Front Power Take-Off
Maximum lift capacity, at link end - kg
Front spool valves
Engine speed @ 1000 front PTO speed - rpm
Wheels and Tyres (Full range available. Please consult your Dealer)
Front - m
Rear - m
Weights and dimensions (with standard wheels and tyres, without ballast, 4WD model, less fuel)
Weight - kg
Overall height - from rear axle centreline to top of roof - m
Overall height - over cab - m
Overall length - from weight carrier to lower link ends - m
Wheelbase - m

MF 6612 Dyna-4	MF 6613 Dyna-4	MF 6615 Dyna-4	MF 6613 Dyna-6	MF 6614 Dyna-6	MF 6615 Dyna-6	MF 6616 Dyna-6	MF 6614 Dyna-VT	MF 6615 Dyna-VT	MF 6616 Dyna-VT
1980 / 2030									
-									
1930 / 1490 / 1900									
1980 / 1530 / 2030 / 1570									
1 3/8									
3200									
1 / 2 / 1 + Pressure & Free Return									
1920									
14.9 R 28					16.9 R 28				
18.4 R 38					20.8 R 38				
5400									
5700									
2.10									
3.08									
4.7									
2.67									

Dimensions

	MF 6600
Wheel drives	4WD
A – Wheelbase - mm	2670
B – Overall length from front weight frame to rear linkage arms - mm	4715
B – Overall length from front weights to rear linkage arms - mm	5129
B – Overall length from front linkage (transport position) to rear linkage arms - mm	5400
C – Height* from rear axle to top of cab with Standard roof - mm	2101
Visioline roof - mm	2120
D – Ground clearance (depending on tractor configuration) - mm	435
*heights without beacon; + 157mm with beacon; +130mm with Auto-Guide™ TopDock antenna	

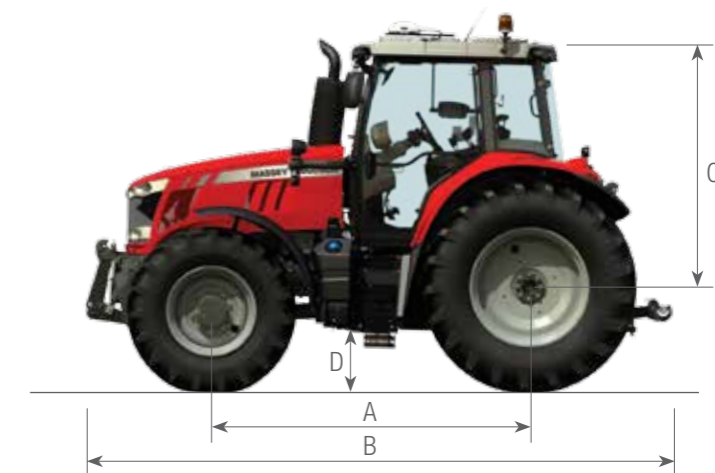



MASSEY FERGUSON

A world of experience. Working with you.



facebook.com/AGCOcorp
twitter.com/AGCOcorp
youtube.com/AGCOcorp
ustream.tv/channel/AGCOchat
blog.agcocorp.com



MASSEY FERGUSON is a worldwide brand of AGCO.
© AGCO Limited. 2013 | 15528/0913 | A-English/0913/0m



Responsible forest management

